

PARTS LIST			
ITEM	QTY	PART NUMBER	DESCRIPTION
1	1	3330321	LARGE A/L COTTER - S/STEEL 304
2	1	3330-251 BOSS	S/STEEL 304 A/L WELD ON BOSS
3	1	3330234	S/STEEL LARGE ROLL PIN

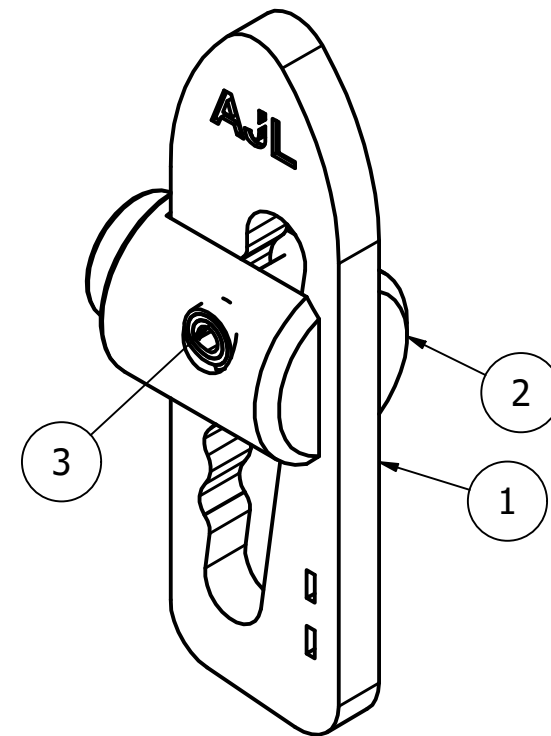
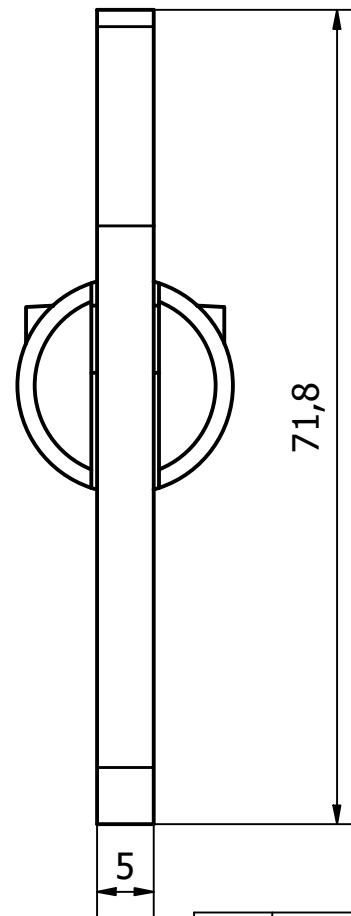
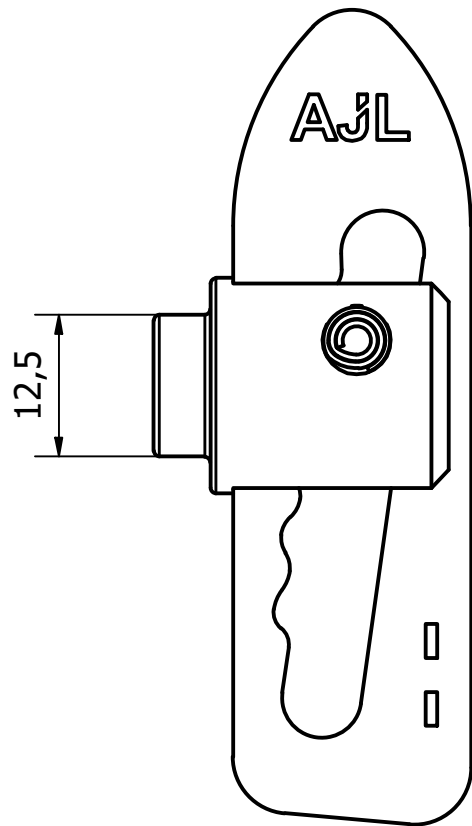
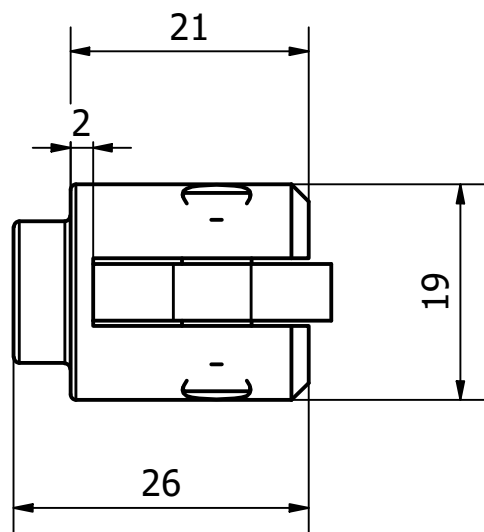

REV	DESCRIPTION	DATE	APPROVED
2	DESIGN UPDATED	24/10/22	U.F
1	VALIDATION COMPLETE	16/06/20	J.C

GENERAL TOLERANCES ON LENGTHS	
0.5 - 6 ± 0.1mm	
6 - 30 ± 0.2mm	
30 - 120 ± 0.3mm	
120 - 400 ± 0.5mm	
400 - 1000 ± 0.8mm	
1000 - 2000 ± 1.2mm	
2000 - 4000 ± 2.0mm	

ALBERT JAGGER LTD  
 GREEN LANE  
 WALSALL PHONE: 01922 471000  
 WEST MIDLANDS FAX: 01922 648021  
 WS2 8HG

THIS DRAWING & THE DESIGN SHOWN ARE THE PROPERTY OF ALBERT JAGGER LTD AND MUST NOT BE USED OR COPIED BY A THIRD PARTY WITHOUT PERMISSION

DRAWN BY  
U.F

CHECKED BY  
J.C

THIRD ANGLE PROJECTION

SCALE  
3 : 2

MATERIAL  
S/STEEL 304

MASS  
0.077 kg

FINISH  
NATURAL

Date  
16/06/2020

ALL DIMS IN MM UNLESS STATED DO NOT SCALE

A3



WELD ON ANTILUCE™ 12.5MM SHANK NO THREAD  
 3330-251

Edition 2	Sheet 1 / 1
--------------	----------------