

A

B

C

D

E

F

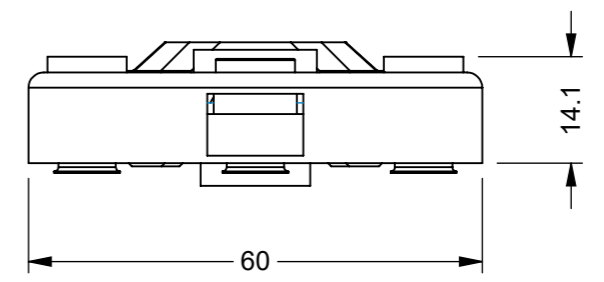
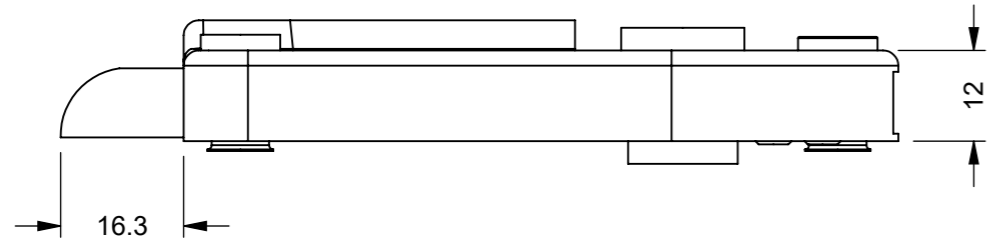
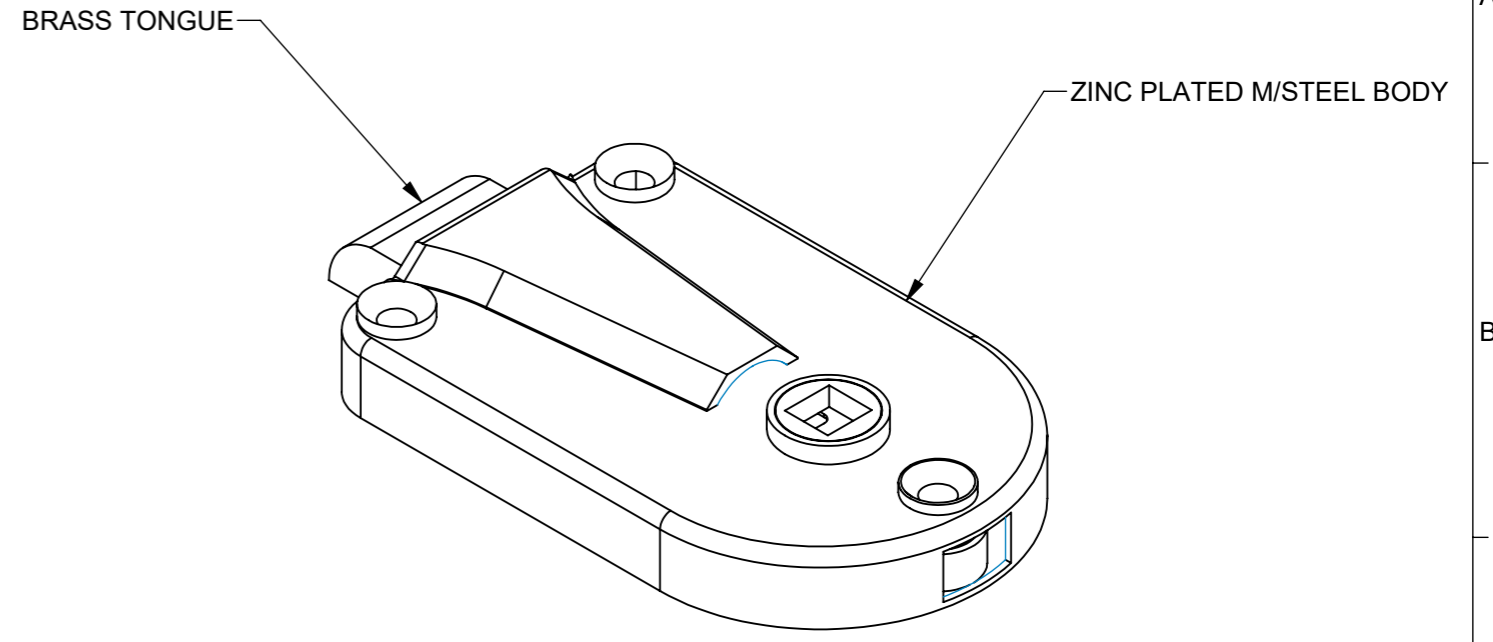
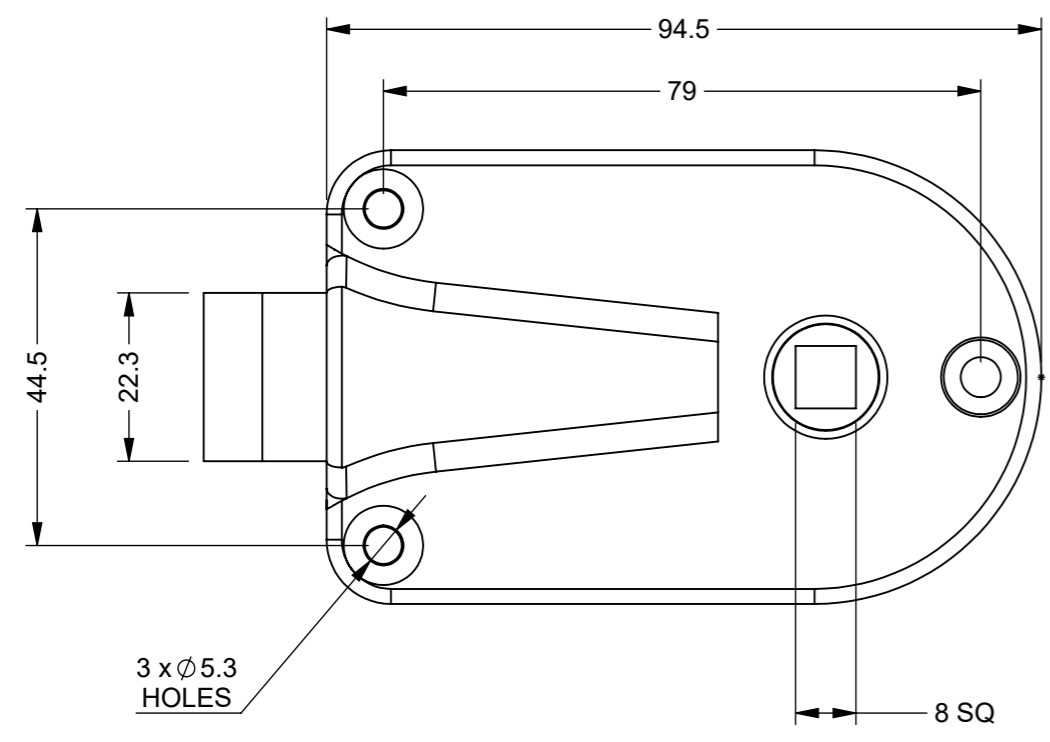

| ZONE | REV. | DESCRIPTION            | DATE       | APPROVED |
|------|------|------------------------|------------|----------|
|      | 2    | RE-DRAWN IN SOLIDWORKS | 18/07/2023 | U.F      |

UNLESS OTHERWISE STATED, ALL DIMENSIONS IN mm

| TOLERANCES            | SURFACE FINISH | FILLET RADII |
|-----------------------|----------------|--------------|
| 0.5 - 6 = ±0.1mm      | 1.6µm Ra       | 0.5 TO 1.0   |
| 6 - 30 = ±0.2 mm      |                |              |
| 30 - 120 = ±0.3 mm    |                |              |
| 120 - 400 = ±0.5 mm   |                |              |
| 400 - 1000 = ±0.8 mm  |                |              |
| 1000 - 2000 = ±1.2 mm |                |              |
| 2000 - 4000 = ±2.0 mm |                |              |

|                       |                 |   |   |               |    |
|-----------------------|-----------------|---|---|---------------|----|
| MATERIAL: SEE DRAWING | DRAWN BY: UF    | DESCRIPTION: L.H SLAM LATCH - NO SAFETY CATCH |   |               | A3 |
| FINISH: SEE DRAWING   | CHECKED BY: A.P | NUMBER: 5589-227                              | REVISION: 2   | SHEET: 1 of 1 |    |
| APPROVED BY: A.P      |                 | ORIGINATION DATE: 18/07/2023                  | SCALE : PROPORTIONAL - DO NOT SCALE<br>REF SCALE 1:1 WHEN PRINTED ON A3 |               |    |

PROPRIETARY RIGHTS ARE INCLUDED IN THE INFORMATION DISCLOSED HEREIN. NEITHER THIS DOCUMENT NOR ANY INFORMATION DISCLOSED SHALL BE REPRODUCED, USED, TRANSFERRED TO OTHER DOCUMENTS, OR DISCLOSED TO OTHERS FOR ANY PURPOSE INCLUDING MANUFACTURING UNLESS SPECIFICALLY AUTHORISED IN WRITING  
REMOVE ALL SHARP EDGES AND BURRS  
PART FINISHING AND MARKING TO CESF001

