

IF IN DOUBT ASK

IF IN DOUBT ASK

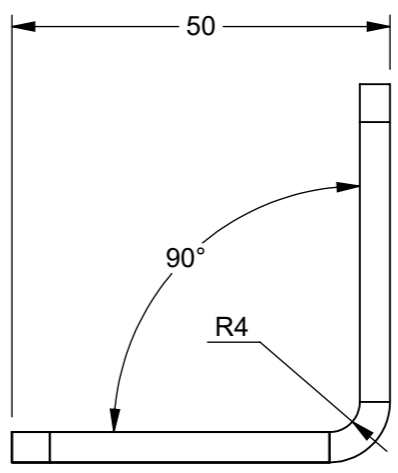
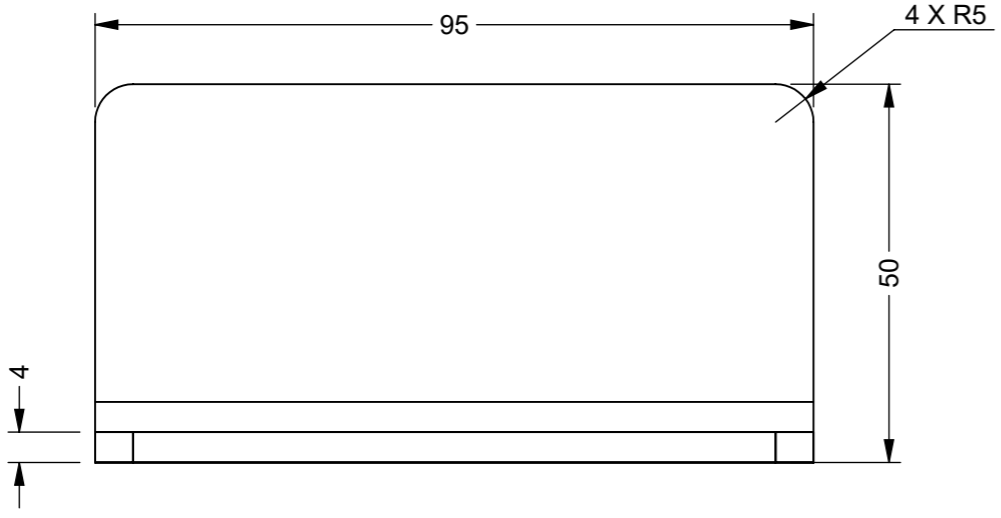
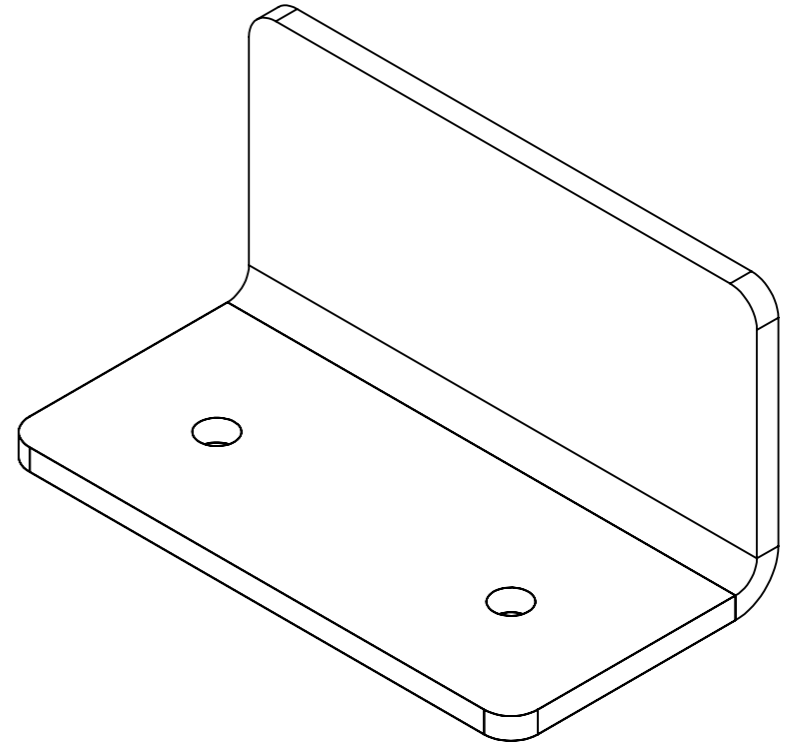
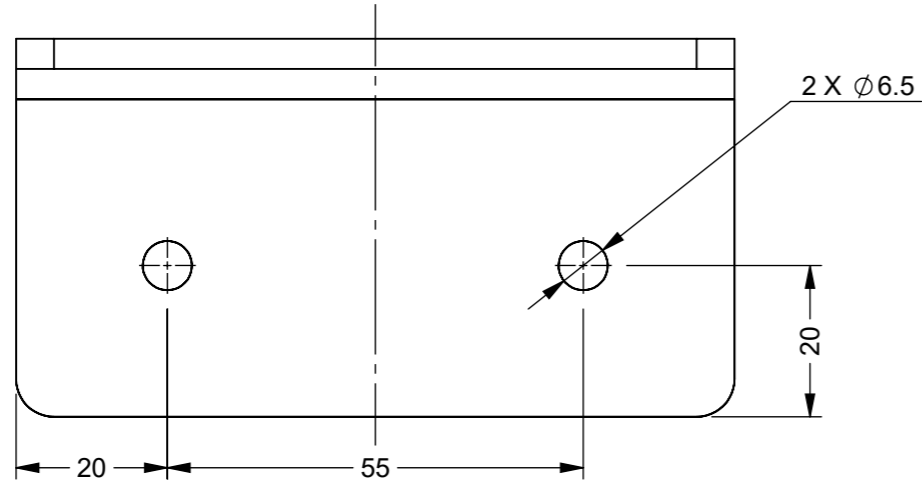

ZONE	REV.	DESCRIPTION	DATE	APPROVED
	1	VALIDATION COMPLETE	15/11/2023	C.H
	A	PART NUMBER ASSIGNED WAS AJ 0966	14/11/2023	L.B.H

REVISIONS

UNLESS OTHERWISE STATED, ALL DIMENSIONS IN mm

TOLERANCES	SURFACE FINISH	FILLET RADII
0.5 - 6 = ±0.1mm	1.6µm Ra	0.5 TO 1.0
6 - 30 = ±0.2 mm		
30 - 120 = ±0.3 mm		
120 - 400 = ±0.5 mm		
400 - 1000 = ±0.8 mm		
1000 - 2000 = ±1.2 mm		
2000 - 4000 = ±2.0 mm		

MATERIAL: M/STEEL-CR4
 MASS: 0.40
 FINISH: ZINC PLATED 8 MICRONS WITH CLEAR JS500 TOP COAT

DRAWN BY: L.B.H
 CHECKED BY: U.F
 DESCRIPTION: FOLDED BRACKET 50 X 95

A3

PROPRIETARY RIGHTS ARE INCLUDED IN THE INFORMATION DISCLOSED HEREIN. NEITHER THIS DOCUMENT NOR ANY INFORMATION DISCLOSED SHALL BE REPRODUCED, USED, TRANSFERRED TO OTHER DOCUMENTS, OR DISCLOSED TO OTHERS FOR ANY PURPOSE INCLUDING MANUFACTURING UNLESS SPECIFICALLY AUTHORISED IN WRITING
 REMOVE ALL SHARP EDGES AND BURRS
 PART FINISHING AND MARKING TO CESF001



APPROVED BY: C.H
 ORIGINATION DATE: 14/11/2023
 NUMBER: 6033- 4848
 REVISION: 1
 SHEET: 1 of 1
 SCALE : PROPORTIONAL - DO NOT SCALE REF SCALE 1:1 WHEN PRINTED ON A3

